

# Sara

35 32 40

serie comunità e scuola, impilabile, ignifuga  
*community and school serie, stackable, fireproof*

anche nelle versioni conformi alla normativa UNI EN 1729-1/2  
*also in the version in accordance with norms UNI EN 1729-1/2*



Sara 35



Sara 32



Sara 40

# Sara 35 32 40



**Sedia impilabile in polipropilene copolimero, tubo Ø 25**  
**Stackable chair in polypropylene copolymer, tube Ø 25**

## SCocca SHELL

Composizione: stampato in materiale termoplastico (polipropilene copolimero) di prima scelta, autoestinguento, additivato con cariche antistatiche e colorato in massa con pigmenti ad alta solidità alla luce (7 e/o 8).

Autoestinguenza: certificazione Classe1 (Italia), M2 (Francia), su richiesta B1 (Germania).

La versione non autoestinguento è disponibile solo su richiesta.

Finitura superficiale: goffatura + zigrinatura antiscivolo (sedile).

Fissaggio: di tipo misto incastro meccanico (accoppiamento con fissatori elastici Ø10 per alberi senza scanalatura in C60) per garantire una maggior stabilità anche a temperature elevate.

Può essere personalizzata sia con testi che con grafiche in modo indelebile nel retroschiena della scocca. Personalizzazione in rilievo, area utile per fotoincisione: largh. 80 mm X h 80 mm.

Composition: moulded with first choice plastic material (polypropylene copolymer), fire retardant, with anti-static additives painted in the mass with pigments high resistant to sunlight (7-8).

Fire retardant: certification Classe 1 (Italy), M2 (France), by request B1 (Germany).

Standard version (not fireproof) available by request.

Surface finishing: embossing + anti-slip graining (for the seat).

Assembling: mixed assembling by dap joint/mechanic (coupling with retaining washer Ø 10 for shafts whitout spile C60) for a better stability even at high temperatures.

Can be personalized with texts and logo printed in indelible way on the back of the shell. It will be made in relief and the photoengraving area will be: width 80 mm X height 80 mm.

PPN

PPI

## TELAIO FRAME

L'intera struttura è impilabile ed è realizzata con tubo Ø 25 mm elettrosaldato formato a freddo, avente 2 traversine in piatto largh. mm 25 spessore mm 4 per l'alloggiamento ed il fissaggio del sedile. Disponibile cromato o verniciato a polveri epossidiche.

The whole structure is stacking and it is realised with tube Ø 25 mm joined by electric welding, cold formed with flat bars 25 mm wide and 4 mm thick for the housing and assembling of the seat.

Available chrome-plated or epoxy painted.

C V

## ACCESSORI ACCESSORIES

Carrello portasedie.  
Trolley for chairs.

## COLORI COLORS

**Clicca qui per vedere i nostri colori standard.**

Siamo in grado di produrre anche colori speciali su richiesta.

**Click here to see our standard colors.**

We can also produce special colors on request.

Altri colori di collana possono essere prodotti per lotti non inferiori a 200 Pz.

Others colours available on demand not less than 200 units.

## DIMENSIONI DIMENSIONS



Sara 32  
Modelli standard  
Standard models

H1: 580-610-650mm  
H2: 305-345mm  
L: 380 mm  
P: 400 mm

Sara 35  
Modelli standard  
Standard models

H1: 730-780-810mm  
H2: 380-425-460mm  
L: 425 mm  
P: 485 mm

Sara 40  
Modelli standard  
Standard models

H1: 745-795-830mm  
H2: 380-420-460mm  
L: 460 mm  
P: 515 mm



Cod. **SARA32G3** Grandezza 3 - *Size Marks 3*

h8	t4	b3	h6	h7	b4	r2	t7	P	H1
345	320*	330	200*	185	380	>300	325	410	695

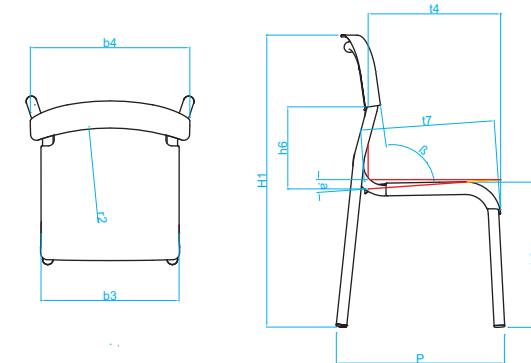

Cod. **SARA35G4** Grandezza 4 - *Size Marks 4*

h8	t4	b3	h6	h7	b4	r2	t7	P	H1
375	355*	360	205*	180	415	>300	380	450	740

Cod. **SARA35G5** Grandezza 5 - *Size Marks 5*

h8	t4	b3	h6	h7	b4	r2	t7	P	H1
430	380*	360	200*	180	410	>300	375	480	785

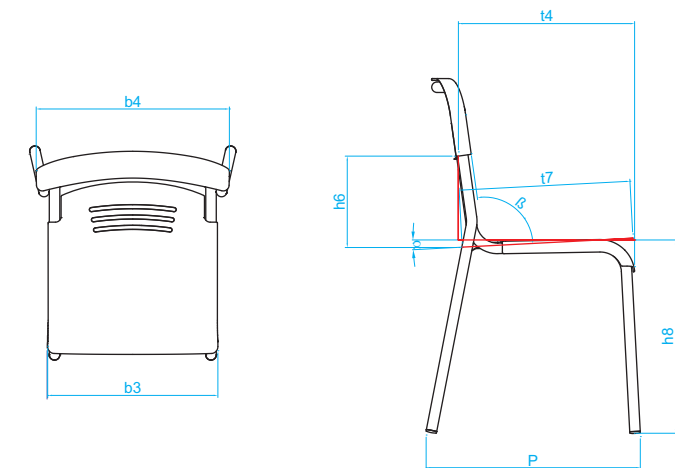

Cod. **SARA40G6** Grandezza 6 - *Size Marks 6*

h8	t4	b3	h6	h7	b4	r2	t7	P	H1
465	415*	405	230*	195	465	>300	410	510	845

Cod. **SARA40G7** Grandezza 7 - *Size Marks 7*

h8	t4	b3	h6	h7	b4	r2	t7	P	H1
505	445*	405	235*	195	465	>300	415	540	905

Tutte le misure lineari sono arrotondate ai multipli di 5mm - *All linear measures are rounded off up to 5 mm.*  
 \* Il risultato è la media di 3 misurazioni - *\*The result is the average of 3 measures.*